INTAKE AND EXHAUST SYSTEM

CONTENTS

EXHAUST MANIFOLD	9	SPECIFICATIONS	3
EXHAUST PIPES AND MUFFLERS	16	General Specifications	3
GENERAL INFORMATION	2	Sealants and Adhesives	4
INTAKE MANIFOLD	5	Service Specifications	3
INTERCOOLER	7	Torque Specifications	3
SERVICE ADJUSTMENT PROCEDURES	4	TURBOCHARGER	10
Turbocharger Supercharging	4		
Pressure Inspection	4		

GENERAL INFORMATION

N11BAAE

The intake manifold is made of an aluminum casting. Engine coolant is circulated through the heat riser located at the injection mixer mounting area in order to improve atomization of air-fuel mixture. In addition, the jet air passage and EGR gas passage are provided and the thermostat housing is installed near No. 1 port. The exhaust manifold is made of an iron casting, and is so designed as to allow installation of turbocharger. The intercooler is of an air-cooling, cross-flow type made of aluminum, and installed at the vehicle front. The turbocharger is a TD05 model. It consists of the turbine wheel cast from iron, compressor wheel made from aluminum alloy, full-floating bearing to support the wheel shaft, casing, turbine housing, compressor housing, etc.

This turbocharger is a water-cooled type and the water jacket located at the lubricating oil inlet area provides the passage for engine coolant. (Refer to GROUP 7 COOLING.)

In addition, the waste gate valve and actuator are installed to control boost pressure.

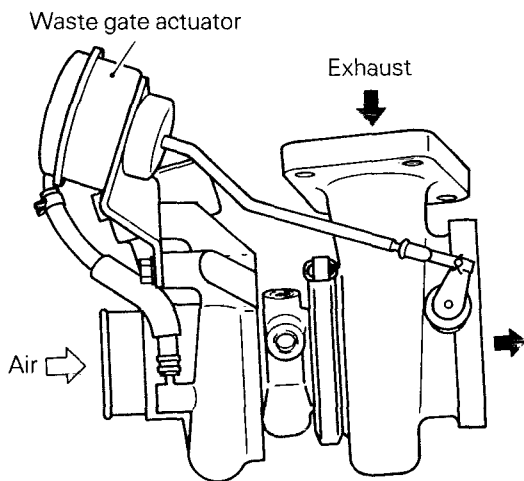

6IN080

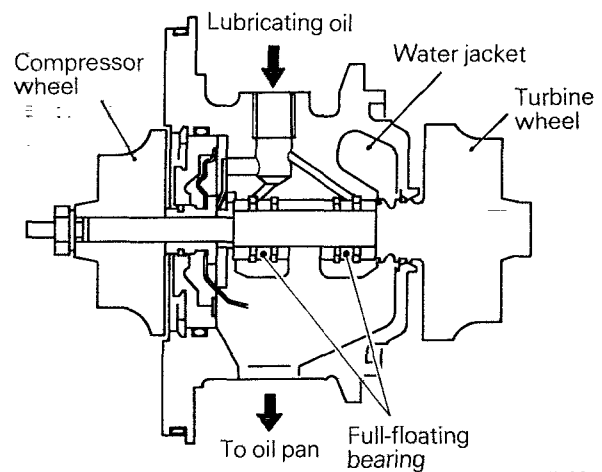

6IN081

SPECIFICATIONS

N11CA--

GENERAL SPECIFICATIONS

Items	Specifications
Turbocharger	
Type	Exhaust gas turbine type
Identification No.	TD05 – 12A – 8
Supercharging pressure control	Waste gate actuator and valve
Intercooler	
Type	Air cooled type
Exhaust system	
Muffler	Expansion resonance type
Coupling	Spherical coupling
Suspension system	Rubber O-rings

SERVICE SPECIFICATIONS

N11CB--

Items	Standard	Limit
Intake and exhaust manifolds		
Distorsion of cylinder head contacting surface mm (in.)	Less than 0.15 (.0059)	0.3 (.012)
Supercharging pressure solenoid valve terminal resistance [at 20°C (68°F)] Ω	36 – 44	
Turbocharger		
Supercharging pressure (at 2,500 rpm) kPa (psi)	45 – 88 (6.6 – 12.8)	
Waste gate valve opening pressure kPa (psi)	Approx. 85 (12.3)	

TORQUE SPECIFICATIONS

N11CC--

Items	Nm	ft.lbs.
Water outlet fitting attaching bolt	10 – 13	7 – 9
Turbocharger coupling bolt	4 – 5	2.9 – 3.6
Waste gate actuator bolt	10 – 13	7.3 – 9.4
Front catalytic converter to manifold	30 – 40	22 – 29
Center exhaust pipe to main muffler	20 – 30	14 – 21
Intercooler air hose band	3 – 5	2 – 4
Turbocharger to exhaust manifold	50 – 70	36 – 51
Catalytic converter to turbocharger	50 – 70	36 – 51
Oil pipe flare nut	16 – 24	12 – 17
Oil return pipe to turbocharger	8 – 10	5.8 – 7.2
Heat protector to turbocharger	8 – 10	5.8 – 7.2
Heat insulator to exhaust manifold	12 – 15	9 – 10
Front catalytic converter to rear catalytic converter	30 – 40	22 – 29

Items	Nm	ft.lbs.
Center exhaust pipe to rear catalytic converter	40 – 60	29 – 43
Intake and exhaust manifold nuts or bolts	15 – 20	11 – 14
Oxygen sensor	25 – 30	18 – 22
Oil pipe joint	22.5 – 27.5	16.3 – 19.9
Oil pipe clamp	12 – 15	9 – 11
Injection mixer to manifold	15 – 20	11 – 14
Water outlet fitting	17 – 20	13 – 14
Compressor bracket bolt	40 – 50 20 – 30	29 – 36 14 – 21

SEALANTS AND ADHESIVES

N11CD

Items	Specified sealant	Quantity
Threads of engine coolant temperature sensor, thermo valve and engine coolant temperature gauge unit	MOPAR Part No. 4318034 or equivalent	As required

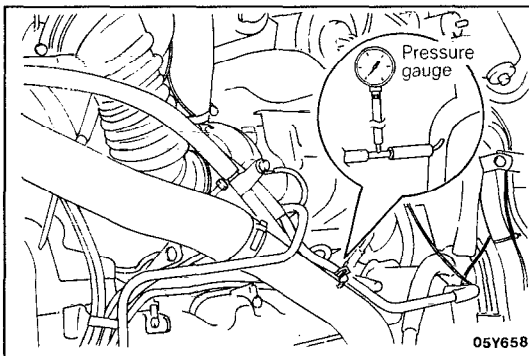

SERVICE ADJUSTMENT PROCEDURES

N11GAAA

TURBOCHARGER SUPERCHARGING PRESSURE INSPECTION

Caution

Perform running inspection with two passengers in the vehicle and where full throttle acceleration can be safely made.

The pressure gauge reading is taken by a front seat passenger.

1. Disconnect the supercharging pressure take-off hose from the air intake pipe nipple and connect a pressure gauge between the hose and the nipple via a 3-way joint.
2. Drive the car with full throttle and accelerate the engine to a speed of more than 2,500 rpm. Measure the supercharging pressure when the pointer is stabilized.

Standard value: 45 – 88 kPa (6.6 – 12.8 psi)

Caution

If the supercharging pressure deviates from the standard value, check the following items for possible causes.

When pressure is high:

Waste gate actuator malfunction (Refer to P.11-15 for inspection of waste gate actuator.)

When pressure is low:

Waste gate actuator malfunction (Refer to P.11-15 for inspection of waste gate actuator.)

Poor engine output

Supercharging pressure leaks

Faulty turbocharger (Refer to P.11-10, 13.)

INTAKE MANIFOLD

N11MA--

REMOVAL AND INSTALLATION

Pre-removal Operation

- Draining Engine Coolant
(Refer to GROUP 0 LUBRICATION AND MAINTENANCE – Replace of the Engine Coolant.)

Post-installation Operation

- Refilling Engine Coolant
(Refer to GROUP 0 LUBRICATION AND MAINTENANCE – Replace of the Engine Coolant.)

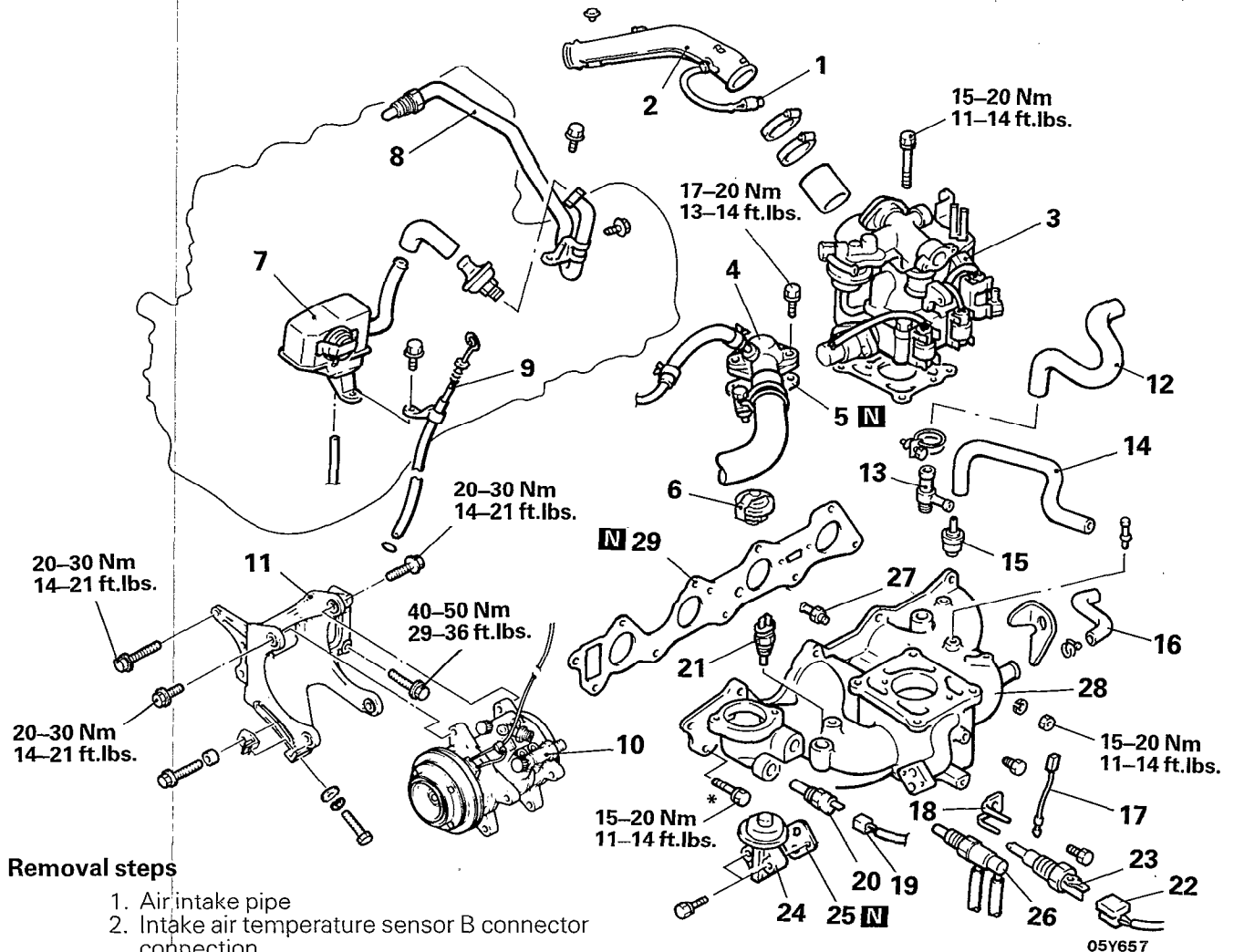

Removal steps

1. Air intake pipe
2. Intake air temperature sensor B connector connection
- ↔ 3. Injection mixer assembly
- ↔ 4. Water outlet fitting
- ↔ 5. Gasket
- ↔ 6. Thermostat
7. Secondary air cleaner assembly (Vehicles with an air conditioner)
8. Secondary air pipe
9. Oil dipstick assembly
- ↔ 10. Compressor and clutch assembly (Vehicles with an air conditioner)
11. Compressor bracket
12. Heater hose
13. Joint
14. Brake booster vacuum hose
15. Water trap
16. Water hose
17. Cable assembly
18. Cable clamp
19. Engine coolant temperature switch harness connector connection (Vehicles with an air conditioner)

20. Engine coolant temperature switch (Vehicles with an air conditioner)
21. Engine coolant temperature sensor
22. Engine coolant temperature gauge unit harness connector connection
23. Engine coolant temperature gauge unit
24. EGR valve
25. Gasket
- ↔ 26. Thermo valve
27. Hose nipple
28. Intake manifold
29. Intake manifold gasket

NOTE

- (1) Reverse the removal procedures to reinstall.
- (2) ↔: Refer to "Service Points of Removal".
- (3) ↔: Refer to "Service Points of Installation".
- (4) **N**: Non-reusable parts
- (5) Of all intake manifold attaching parts, only this part marked with * is a bolt.

SERVICE POINTS OF REMOVAL

N11MBAE

3. REMOVAL OF INJECTION MIXER ASSEMBLY

Refer to GROUP 14 FUEL SYSTEM.

6. REMOVAL OF THERMOSTAT

Refer to GROUP 7 COOLING.

10. REMOVAL OF COMPRESSOR AND CLUTCH ASSEMBLY

Remove the compressor and clutch assembly with the hose connected.

NOTE

If hose is disconnected, gas charge is required.

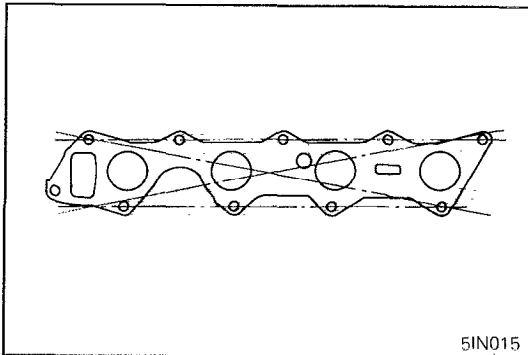
**INSPECTION**

N11MCAG

INTAKE MANIFOLD

Check the points described below; replace the part if a problem is found.

- (1) Damage or cracking of any part.
- (2) Clogging of the negative pressure (vacuum) outlet port, or clogging of the water or gas passages.
- (3) Check, by using a straight edge and feeler gauge, for distortion of the cylinder head installation surface.

Standard value: 0.15 mm (.0059 in.)**Limit: 0.3 mm (.012 in.)****SERVICE POINT OF INSTALLATION**

N11MDAI

26. APPLICATION OF SEALANT TO THERMO VALVE**Specified sealant: MOPAR Part No. 4318034 or equivalent**

INTERCOOLER

REMOVAL AND INSTALLATION

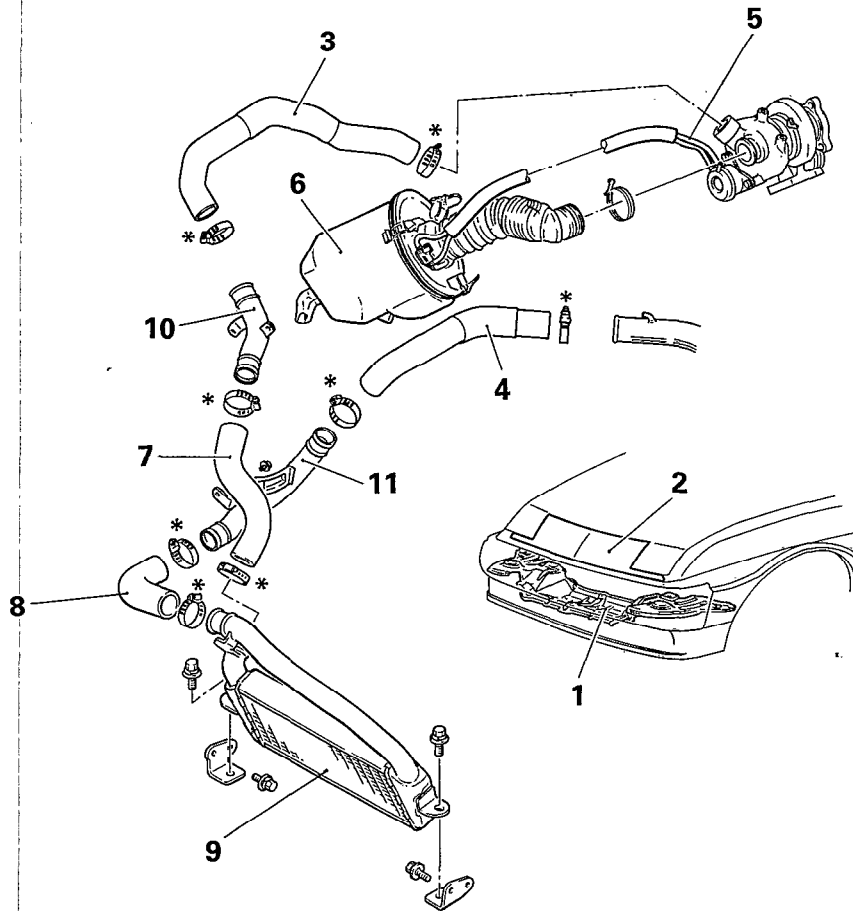

Removal steps

1. Air guide panel assembly
2. Header panel
3. Air hose A
4. Air hose D
5. Vacuum hose connection
6. Air cleaner
7. Air hose B
8. Air hose C
- ↔ ↔ ↔ 9. Intercooler
10. Air pipe A
11. Air pipe B

05Y655

NOTE

- (1) Reverse the removal procedures to reinstall.
- (2) ↔: Refer to "Service Points of Removal".
- (3) ↔: Refer to "Service Points of Installation".
- (4) Torque for tightening hose band marked with * is 3 – 5 Nm (2 – 4 ft.lbs.).

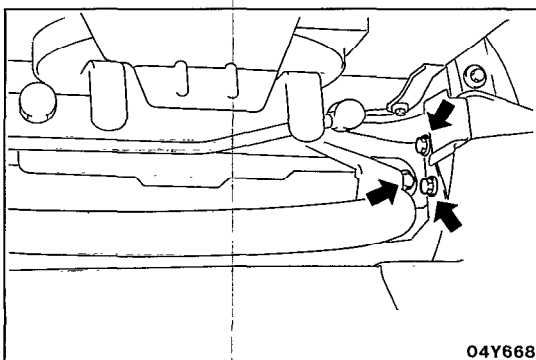

04Y668

SERVICE POINT OF REMOVAL

N11TBAA

9. REMOVAL OF INTERCOOLER

Remove the intercooler bracket (right side) and the intercooler mounting bolts and remove the intercooler from below.

INSPECTION

N11TCAA

- Check the intercooler fins for bending, damage, or foreign matter.
- Check the intercooler hoses for cracking, damage, or wear.

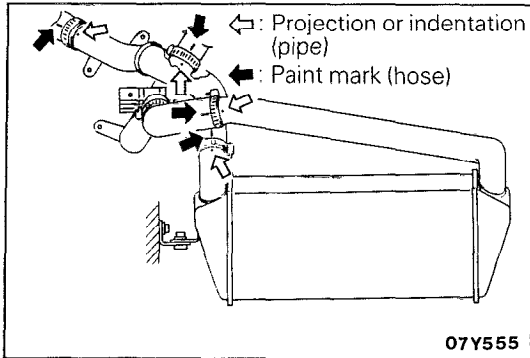
**SERVICE POINT OF INSTALLATION**

N11TDAA

9. INSTALLATION OF INTERCOOLER

Connect the air hoses and air pipes by aligning the paint marks on the hoses with the projections and indentations on the pipes.

Caution

Be careful not to allow any foreign matter to get into the hoses, pipes, or the intercooler itself.

**EXHAUST MANIFOLD
REMOVAL AND INSTALLATION**

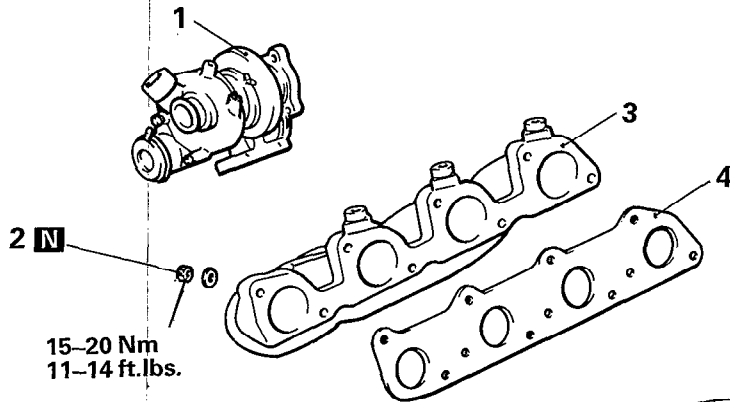

15-20 Nm
11-14 ft.lbs.

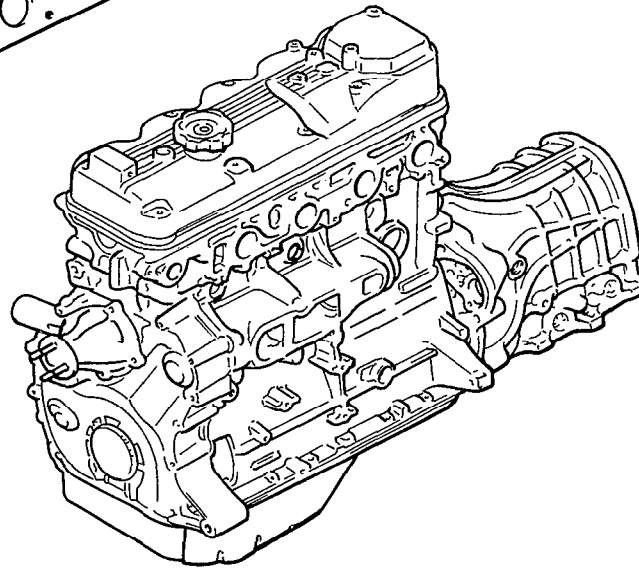

Removal steps

- ◄◄ ►► 1. Turbocharger
- ◄◄ ►► 2. Self-locking nut
- ◄◄ ►► 3. Exhaust manifold
- ◄◄ ►► 4. Exhaust manifold gasket

NOTE

- (1) Reverse the removal procedures to reinstall.
- (2) ◄◄ ►►: Refer to "Service Points of Removal".
- (3) ►► ◄◄: Refer to "Service Points of Installation".

01Y689

SERVICE POINT OF REMOVAL

N11NBAJ

1. REMOVAL OF TURBOCHARGER

Refer to P.11-10.

INSPECTION

N11NCAB

EXHAUST MANIFOLD

Check the points described below; replace the part if a problem is found.

- (1) Damage or cracking of any part.
- (2) Check, by using a straight edge and feeler gauge, for distortion of the cylinder head installation surface.

Standard value: Less than 0.15 mm (.0059 in.)

Limit: 0.3 mm (.012 in.)

EXHAUST MANIFOLD GASKET

Gasket may be reused if it has no peeled-off or damaged surface.

SERVICE POINT OF INSTALLATION

N11NDAC

1. INSTALLATION OF TURBOCHARGER

Refer to P.11-10.

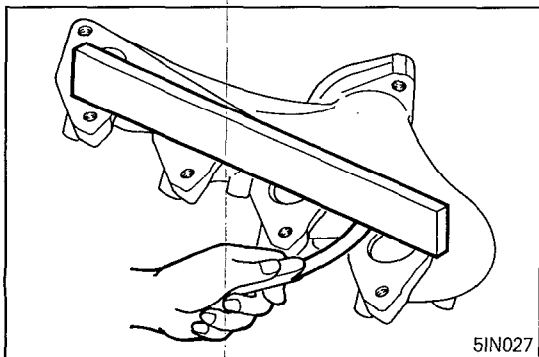

5IN027

TURBOCHARGER

REMOVAL AND INSTALLATION

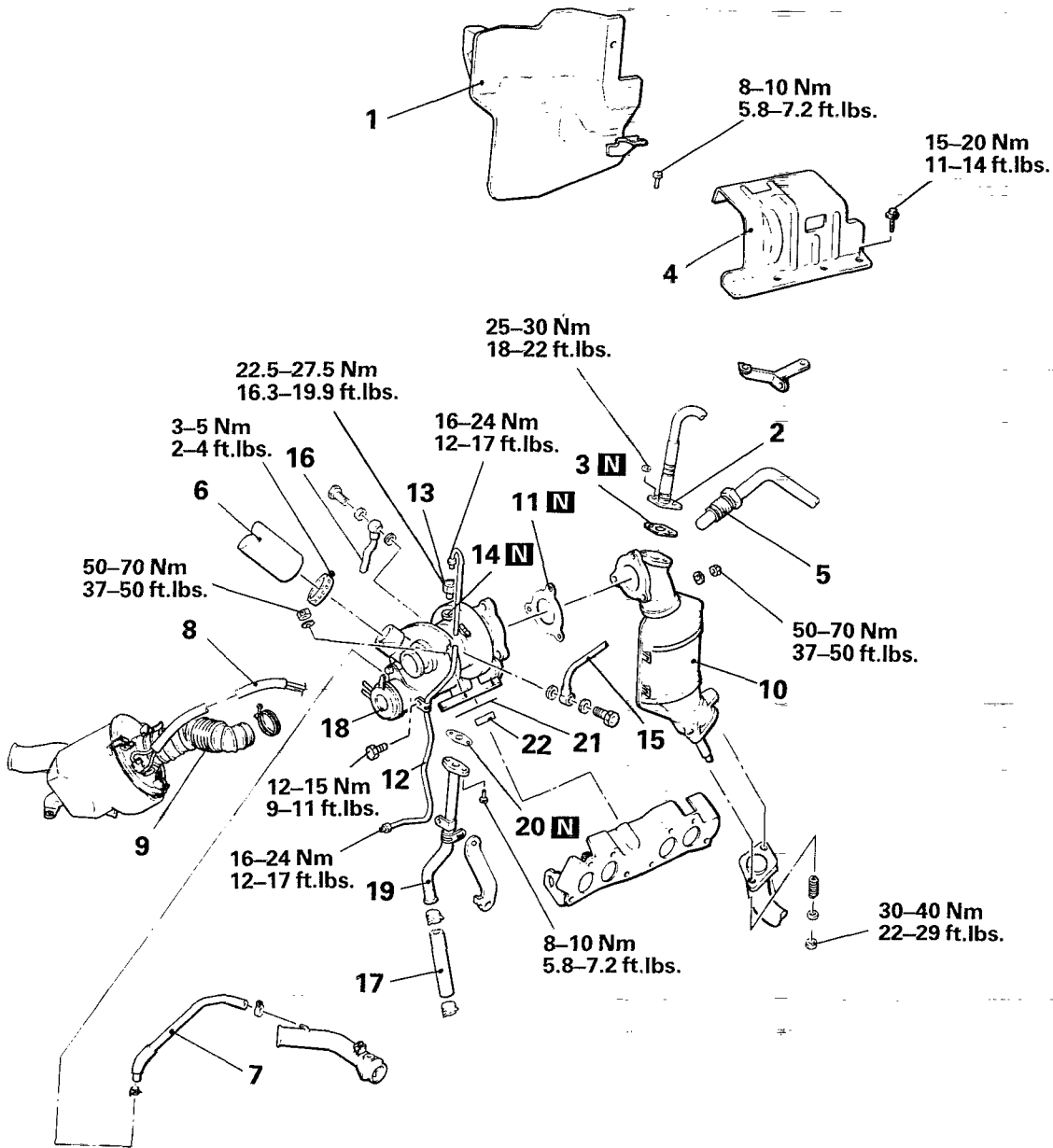

Removal steps

- 1. Heat protector
- 2. Oxygen sensor
- 3. Gasket
- 4. Heat protector
- 5. Secondary air pipe
- 6. Air hose A
- 7. Boost hose
- 8. Vacuum hose connection
- 9. Air intake hose
- 10. Catalytic converter
- 11. Gasket
- 12. Oil pipe
- 13. Oil pipe joint

- 14. Gasket
- 15. Water pipe A
- 16. Water pipe B
- 17. Oil hose
- 18. Turbocharger
- 19. Oil return pipe
- 20. Gasket
- 21. Gasket
- 22. Ring

NOTE

- (1) Reverse the removal procedures to reinstall.
- (2) ↔: Refer to "Service Points of Removal".
- (3) ↔: Refer to "Service Points of Installation".
- (4) [N]: Non-reusable parts

05Y656

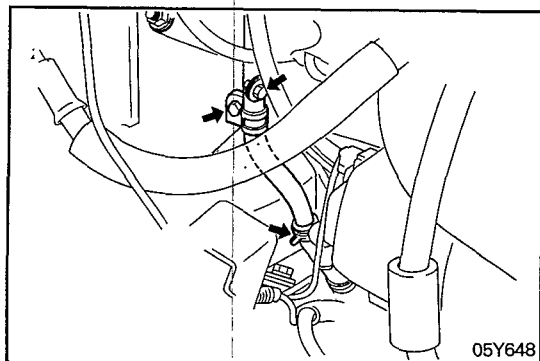
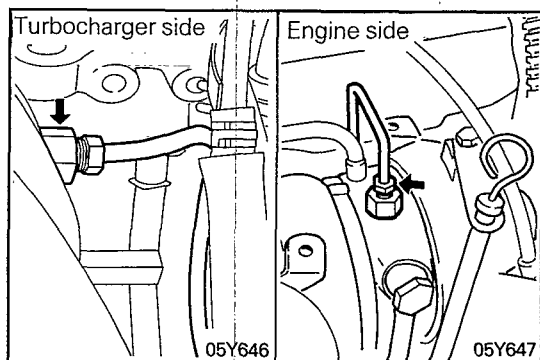

SERVICE POINTS OF REMOVAL

N11LBAB

12. REMOVAL OF OIL PIPE

Remove the oil pipe.

Caution

Do not allow foreign matter to get into the oil path of the turbocharger.

18. REMOVAL OF TURBOCHARGER

- (1) Remove the oil return pipe clamp.
- (2) Remove the turbocharger attaching nuts and remove the turbocharger with oil return pipe installed.

INSPECTION

N11LCAB

- Check the oil pipe for clogging, collapse or deformation.
- Check the oil return pipe for clogging, collapse or deformation.
- Check the turbine wheel and compressor wheel for damage.
- Check the gasket for damage, corrosion and deformation.

INSPECTION OF SUPERCHARGING PRESSURE RELIEF SOLENOID VALVE

- (1) Disconnect the vacuum hoses (blue striped, yellow striped, white striped) from the solenoid valve.

NOTE

Before disconnecting the hoses, mark them to ensure correct reconnection at their original positions.

- (2) Remove the connector.

- (3) Connect a hand vacuum pump to the nipple to which the blue striped vacuum hose has been connected.
- (4) Apply the battery voltage to the solenoid valve terminals to create negative pressure, and check air tightness when the nipple to which the yellow striped hose has been connected is both open and closed.

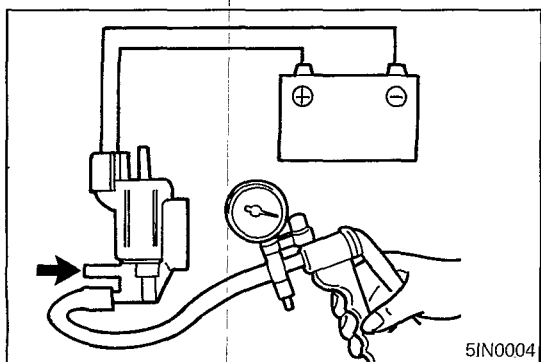

Nipple condition	Normal condition
Open	Negative pressure leaks
Closed	Negative pressure is maintained

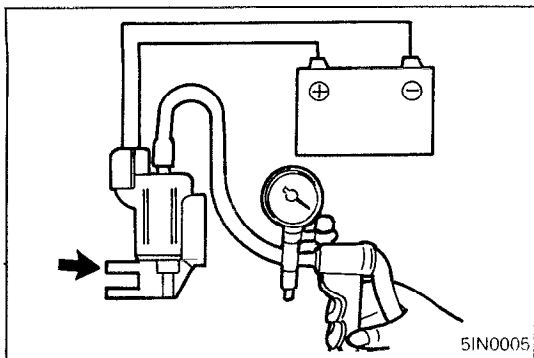

- (5) Connect a hand vacuum pump to the nipple to which the white striped vacuum hose has been connected.
- (6) Apply the battery voltage to the solenoid valve terminals to create negative pressure, and check air tightness when the nipple to which the yellow striped hose has been connected is both open and closed.

Nipple condition	Normal condition
Open	Negative pressure leaks
Closed	Negative pressure is maintained

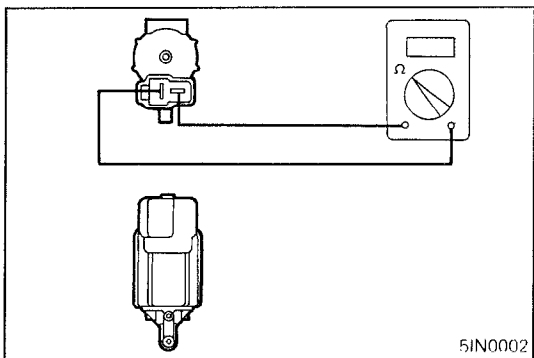

- (7) Measure the solenoid valve terminal resistance:

Standard value: 36 – 44 Ω [at 20°C (68°F)]

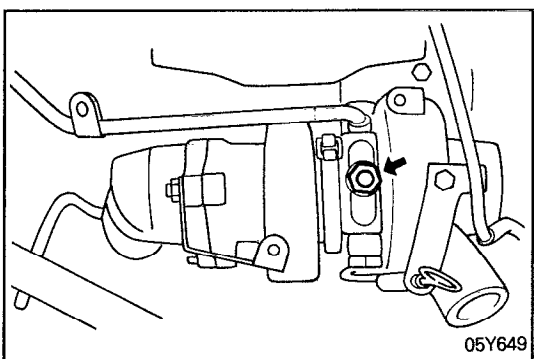

SERVICE POINTS OF INSTALLATION

N11LDAB

12. INSTALLATION OF OIL PIPE

Before installing the flare nut on the oil pipe turbocharger side, pour a small amount of engine oil in the oil path.

10. INSTALLATION OF CATALYTIC CONVERTER

When installing the catalytic converter or exhaust fitting, tighten temporarily the turbocharger side first and then the exhaust pipe side. Then, tighten to specified torque.

TURBOCHARGER

DISASSEMBLY AND REASSEMBLY

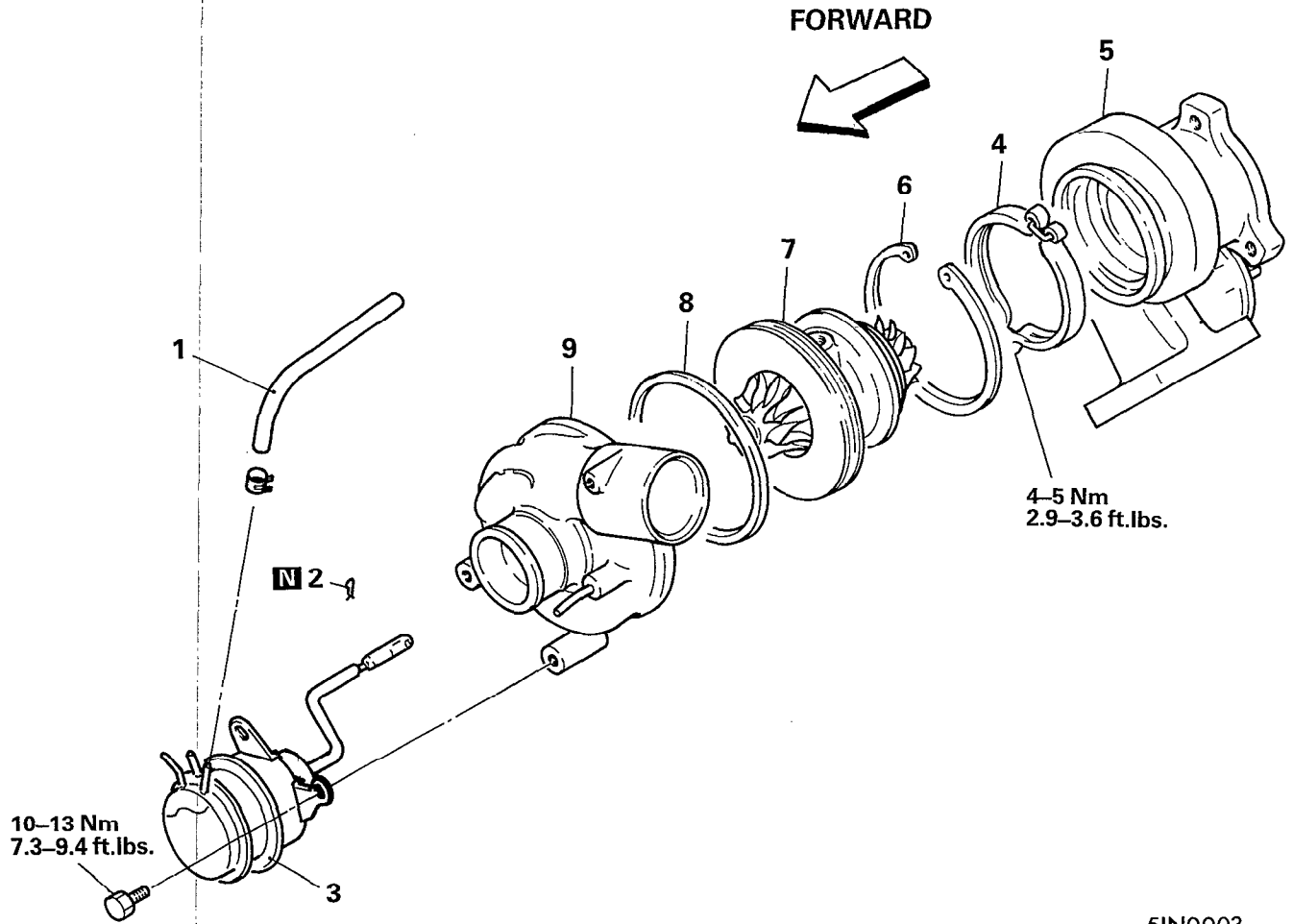

Disassembly steps

1. Boost hose
2. Snap pin
3. Waste gate actuator
4. Coupling
- ↔ ↔ 5. Turbine housing
- ↔ ↔ 6. Snap ring
- ↔ ↔ 7. Cartridge assembly
- ↔ 8. O-ring
9. Compressor cover

NOTE

- (1) Reverse the disassembly procedures to reassemble.
- (2) ↔: Refer to "Service Points of Disassembly".
- (3) ↔: Refer to "Service Points of Reassembly".
- (4) **N**: Non reusable parts

SERVICE POINTS OF DISASSEMBLY

5. REMOVAL OF TURBINE HOUSING

Before turbocharger is disassembled, make match marks on turbine housing, cartridge and compressor cover.

Caution

Never attempt to adjust the waste gate valve.

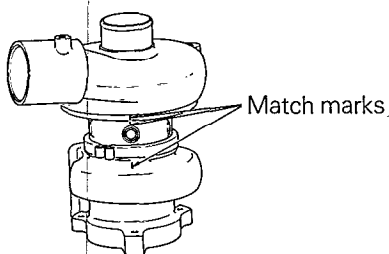

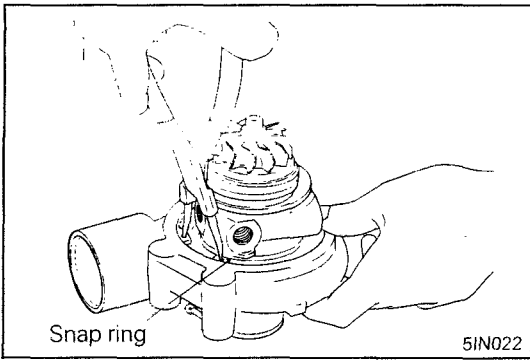

6. REMOVAL OF SNAP RING

Place the compressor cover assembly on floor with its end surface down and remove the snap ring with pliers.

Caution

During removal, hold with a finger the snap ring which can spring out.

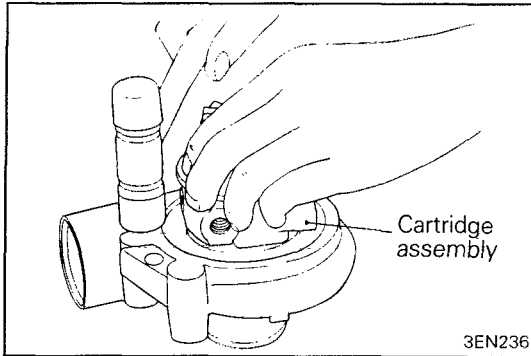

7. REMOVAL OF CARTRIDGE ASSEMBLY

Remove the cartridge assembly by tapping the compressor cover with a soft hammer.

Caution

Some resistance will be experienced in the removal due to the O-ring on cartridge assembly.

INSPECTION

N11LGAA

TURBOCHARGER

- (1) Inspect the cast-iron turbine housing for damage, cracks, or evidence of contact between the turbine blades and the housing.
- (2) Manually open and close the waste gate valve to make sure it operates freely.
- (3) Inspect the turbine and compressor wheels for wear, damage, bent or broken blades.
- (4) Inspect the oil passage in the cartridge for signs of deposits or blockage.
- (5) Clean the inlet section of the compressor cover with a rag. Inspect it for signs of contact with the compressor turbine. If worn, replace it.

WASTE GATE ACTUATOR

- (1) Leak-test the waste gate valve actuator with a hand pump. Replace the actuator if leakage indicates a ruptured diaphragm.
- (2) Check the rod to see that it is not bent or binding so as to require replacement.

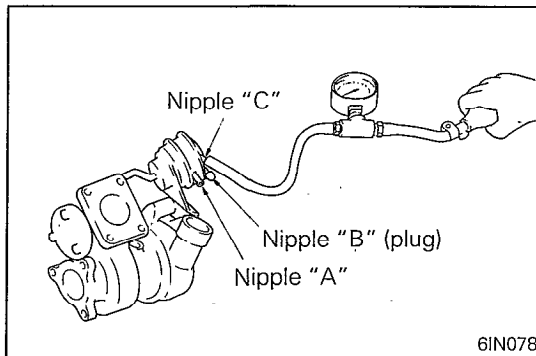
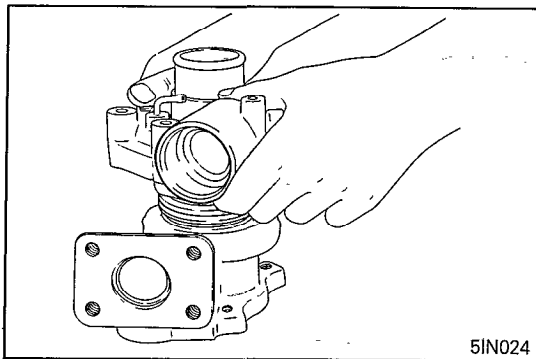
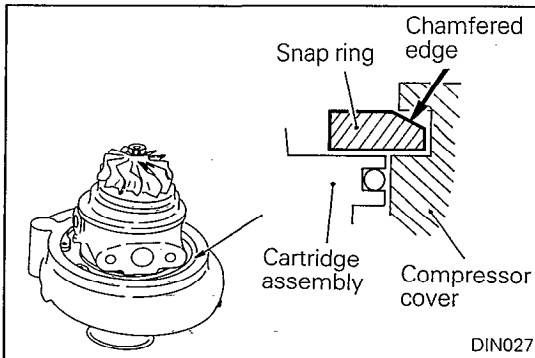
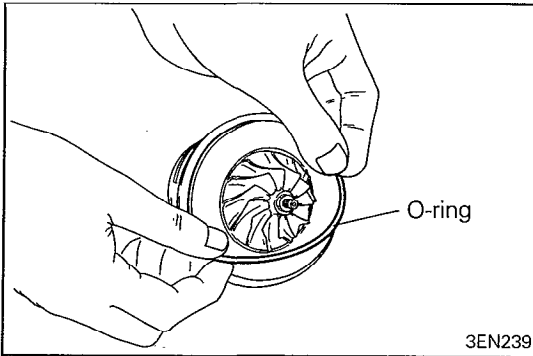

SERVICE POINTS OF REASSEMBLY

N11LHAA

8. INSTALLATION OF O-RING

- (1) Apply thin coat of engine oil to the inside of new O-ring and insert it in the groove in cartridge assembly.

Caution

When O-ring is installed, be careful not to damage O-ring. Otherwise, oil leaks may result.

- (2) Apply thin coat of engine oil to the outside surface of O-ring installed in cartridge assembly. Then install cartridge assembly to compressor cover.

Caution

When cartridge assembly is installed to compressor cover, be careful not to damage vanes of cartridge assembly.

6. INSTALLATION OF SNAP RING

Install snap ring with compressor cover side down.

Caution

Install snap ring with taper surface up.

5. INSTALLATION OF TURBINE HOUSING

- (1) Place the compressor cover with cartridge assembly inside on floor with its end surface down and install the snap ring.
- (2) Combine the compressor cover and cartridge assembly with the turbine housing.

Caution

Do not damage the cartridge assembly vanes.

TEST OF WASTE GATE ACTUATOR OPERATION

N11LIAC

OPERATION CHECK OF WASTE GATE ACTUATOR

- (1) Connect the tester to nipple "C". Open up nipple "A" to the atmosphere.
- (2) Plug nipple "B".
- (3) Apply pressure to the actuator and check that the rod moves.

Applied pressure value: Approx. 85 kPa (12.3 psi)

Caution

Do not apply a pressure of more than 100 kPa (14.5 psi) to the actuator. Otherwise, diaphragm may be damaged.

Never attempt to adjust the waste gate valve.

EXHAUST PIPES AND MUFFLERS

N11RA

REMOVAL AND INSTALLATION

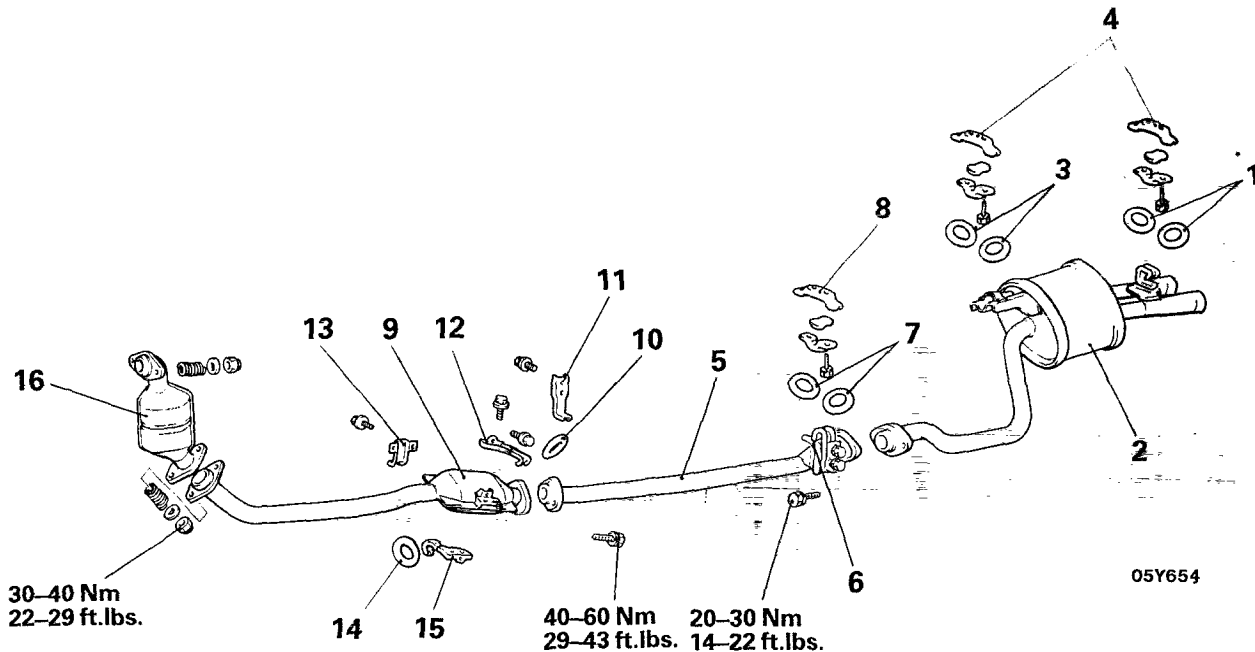

Removal steps

- ↔ 1. O-ring
- ↔ 2. Main muffler
- ↔ 3. O-ring
- ↔ 4. Hanger
- ↔ 5. Center exhaust pipe
- ↔ 6. Hook
- ↔ 7. O-ring
- ↔ 8. Hanger
- ↔ 9. Rear catalytic converter
- ↔ 10. O-ring

- 11. Hanger
- 12. Bracket
- 13. Hanger
- ↔ 14. O-ring
- 15. Bracket
- 16. Front catalytic converter

NOTE

- (1) Reverse the removal procedures to reinstall.
- (2) ↔: Refer to "Service Points of Removal".

INSPECTION

N11RCAF

- Check the mufflers and pipes for corrosion and damage.
- Check suspenders and O-rings for wear and cracks.
- Check the heat protector for corrosion and damage.

SERVICE POINTS OF INSTALLATION

N11RDAF

14. INSTALLATION OF O-RING / 10. O-RING / 7. O-RING / 3. O-RING / 1. O-RING

- (1) Install the rubber O-rings so that they are identical (left and right) in length.
- (2) Tighten the parts securely, and then confirm that there is no interference with any body components.
- (3) After installation, confirm that there is no gas leakage from mufflers and pipes.

