PROPELLER SHAFT AND UNIVERSAL JOINTS

CONTENTS

GENERAL INFORMATION	2	Service Specifications	2
PROPELLER SHAFT	4	Torque Specifications	2
SPECIFICATIONS	2	TROUBLESHOOTING	3
General Specifications	2	Noise and Vibration at High Speed	
Lubricants	2	Noise at Start	

16-2 PROPELLER SHAFT AND UNIVERSAL JOINTS — General Information / Specifications

GENERAL INFORMATION

N16BAAC

The propeller shaft is of two-joint type and the universal joint bearings are lubrication-free.

SPECIFICATIONS

N16CA

GENERAL SPECIFICATIONS

Items	Specifications
Propeller shaft Type Length x O.D. Vehicles with a manual transmission mm (in.) Vehicles with an automatic transmission mm (in.)	Two-joint type 722 x 75 (28.4 x 2.9) 538 x 75 (21.2 x 2.9)
Universal joint Type Bearing Journal O.D. mm (in.)	Cross type Lubrication-free needle roller bearing 14.7 (.58)

SERVICE SPECIFICATIONS

N16CB

Items	Specifications
Standard value Journal end play mm (in.)	0.06 (.0024)
Limit Propeller shaft runout (Dial indicator reading) mm (in.)	0.6 (.024)

TORQUE SPECIFICATIONS

N16CC

Items	Nm	ft.lbs.
Flange yoke attaching bolts	50 – 60	36 – 43

LUBRICANTS

N16CD

Items	Specified lubricant	Quantity
Universal joint	MOPAR Multi-Mileage Lubricant Part No. 2525035 or equivalent	As required
Sleeve yoke surface	MOPAR Hypoid Gear Oil Part No. 3744994 or equivalent	As required

TROUBLESHOOTING

N16EAAB

Symptom	Probable cause	Remedy
Noise at start	Worn journal bearing Worn sleeve yoke spline	Replace
	Loose propeller shaft installation	Retighten
Noise and vibration at high speed	Unbalanced propeller shaft	Replace
	Improper snap ring selection	Adjust the clearance
	Worn journal bearing	Replace

**PROPELLER SHAFT
REMOVAL AND INSTALLATION**

N16GA-

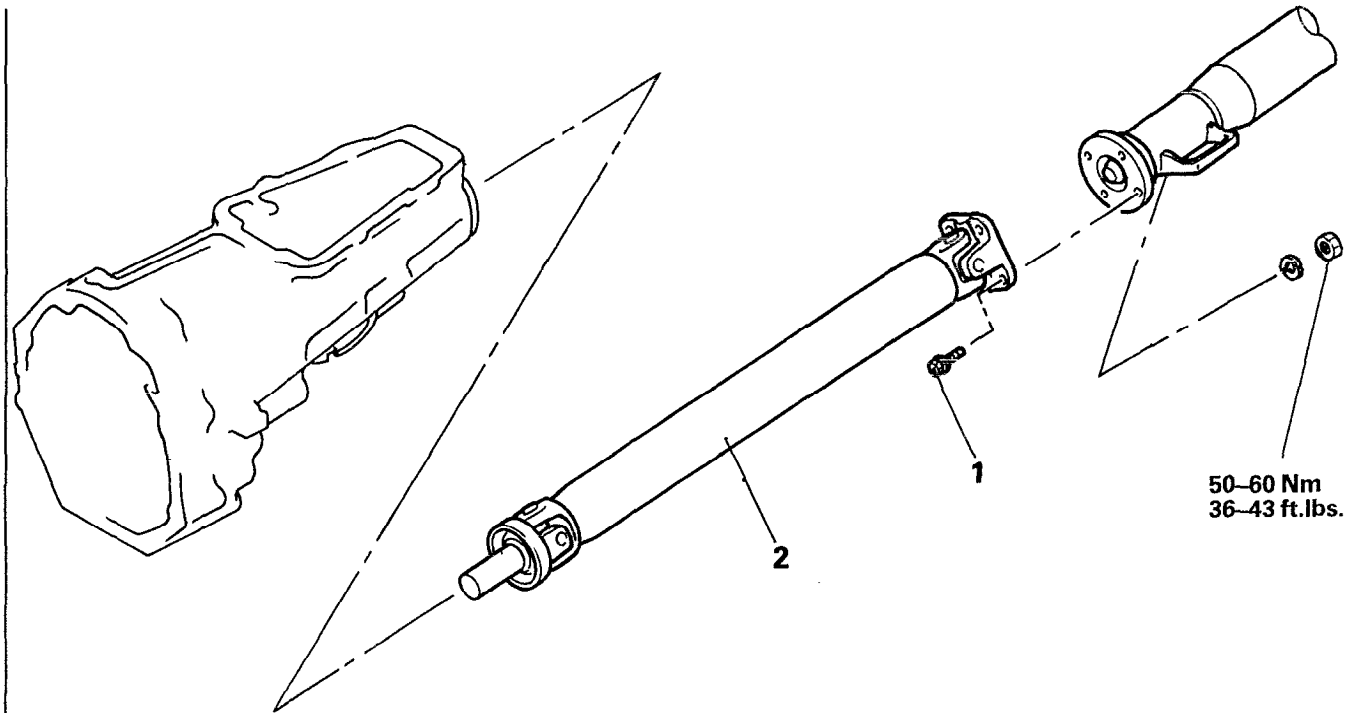

Removal steps

- 1. Flange yoke attaching bolt
- 2. Propeller shaft

NOTE
 (1) Reverse the removal procedures to reinstall.
 (2) ◄◄: Refer to "Service Points of Removal"
 (3) ◄◄: Refer to "Service Points of Installation"

10Y637

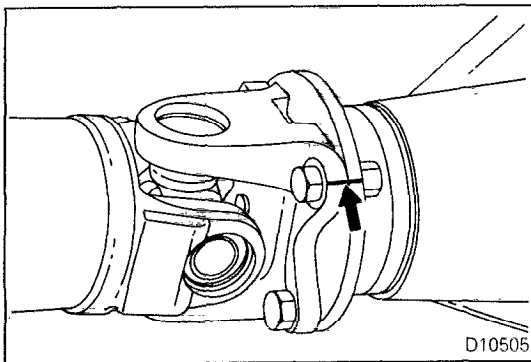

D10505

SERVICE POINT OF REMOVAL

N16GBAC

2. REMOVAL OF PROPELLER SHAFT

Make the mating marks on the flange yoke and the differential companion flange.

Caution

**Use care not to damage the lip of transmission oil seal.
Do not allow foreign matter to enter the transmission.**

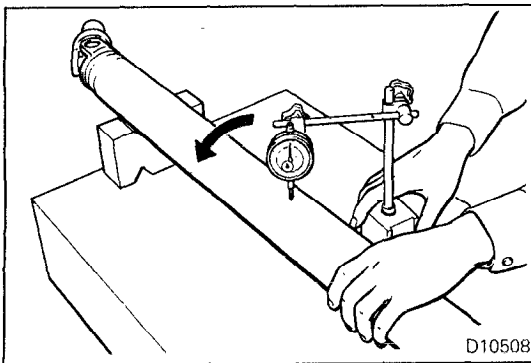

D10508

INSPECTION

N16GCAC

PROPELLER SHAFT RUNOUT

Measure the propeller shaft runout.
If the runout exceeds the limit, replace the propeller shaft.

Limit: 0.6 mm (.024 in.)

- Wear and damage on splines of flange/sleeve yoke
- Cracks of propeller shaft yoke

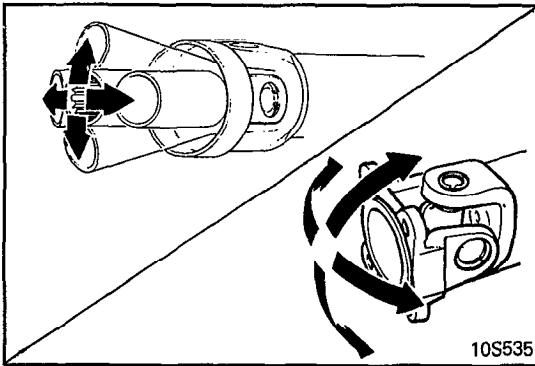

- Smooth operation of universal joints.

SERVICE POINT OF INSTALLATION

N16GDAD

2. INSTALLATION OF PROPELLER SHAFT

Clean the external periphery of the sleeve yoke and apply specified transmission gear oil to the sleeve yoke.

Specified transmission oil: MOPAR Hypoid Gear Oil Part No. 3744994 or equivalent

DISASSEMBLY AND REASSEMBLY

N16GE-

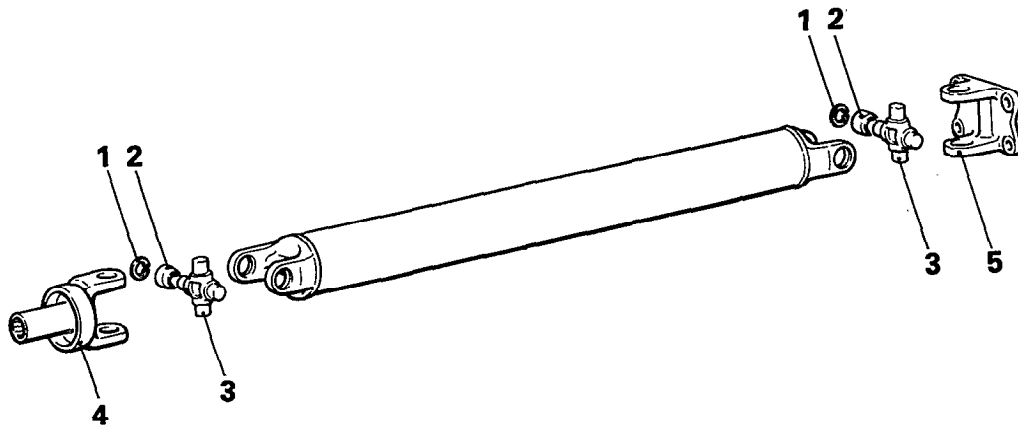

Disassembly steps

- ◄◄ ◄◄ 1. Snap ring
- ◄◄ ◄◄ 2. Journal bearing
- ◄◄ ◄◄ 3. Journal
- ◄◄ ◄◄ 4. Sleeve yoke
- ◄◄ ◄◄ 5. Flange yoke

NOTE

- (1) Reverse the disassembly procedures to reassemble.
- (2) ◄◄: Refer to "Service Points of Disassembly".
- (3) ◄◄: Refer to "Service Points of Reassembly".

10Y623

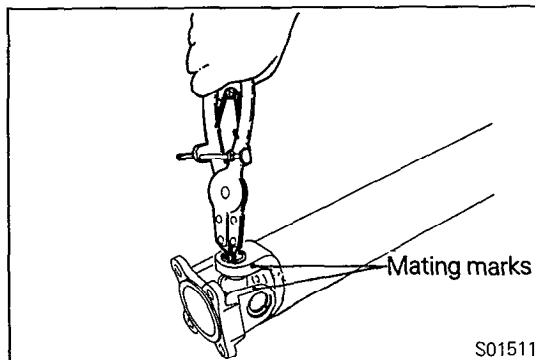

SERVICE POINTS OF DISASSEMBLY

N16GFAG

1. REMOVAL OF SNAP RING

- (1) Make mating marks on the yokes of the universal joint that is to be disassembled.

NOTE

When the universal joint journal and journal bearing are replaced, obtain the universal joint kit.

- (2) Remove the snap rings from the yoke with snap ring pliers.

S01511

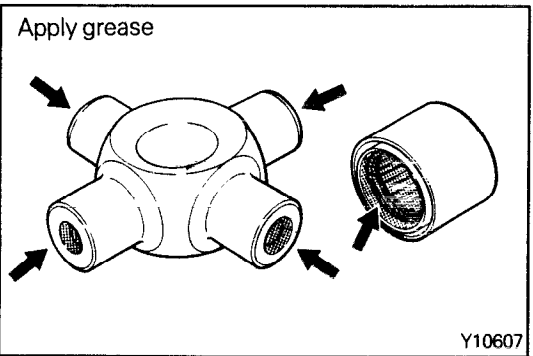
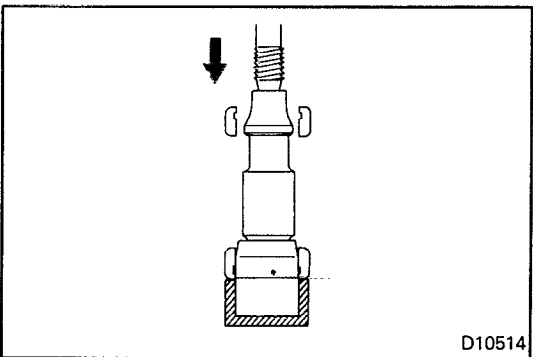
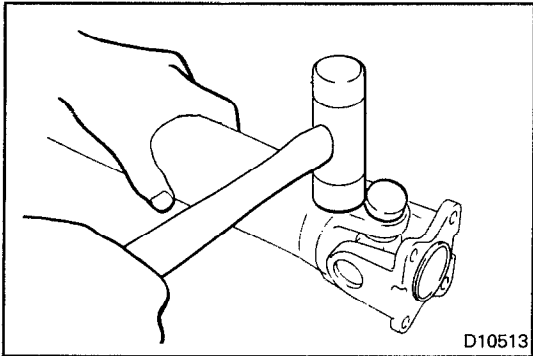
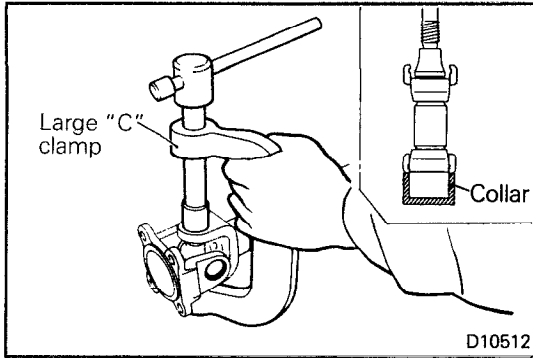

2. REMOVAL OF JOURNAL BEARING / 3. JOURNAL

(1) Force out the journal bearings from the propeller shaft yoke with a large "C" clamp by the following procedures:

- ① Install collar to the large "C" clamp proper.
- ② Press a journal bearing by using the large "C" clamp to force out the journal bearing on opposite side.

③ Pull out the journal bearing from the yoke.

NOTE:

If the journal bearing is hard to remove, strike the yoke with a plastic hammer.

④ Press the journal shaft by using the large "C" clamp to force out the remaining bearings.

⑤ Pull out the journal.

(2) Separate the journal together with the yoke from the propeller shaft yoke.

(3) Force out the journal bearings from the yoke and then take out the journal from the yoke.

SERVICE POINTS OF REASSEMBLY

N16GHAJ

3. INSTALLATION OF JOURNAL / 2. JOURNAL BEARING

(1) Apply specified grease to the following parts of universal joint kit:

- ① Shafts and grease sumps of journal
- ② Dust seal lips
- ③ Needle roller of bearings

Specified grease: MOPAR Multi-Mileage Lubricant Part No. 2525035 or equivalent

Caution

Do not excessively apply grease. Otherwise, faulty fitting of bearing caps and errors in the selection of snap rings may result.

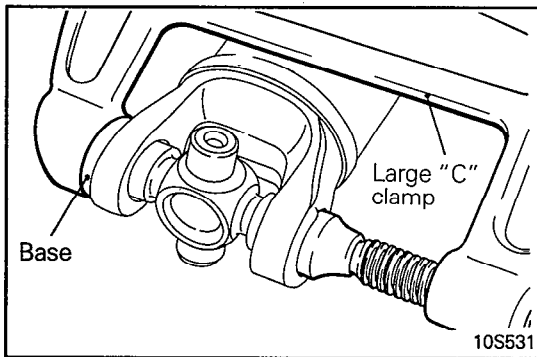

- (2) Press-fit the journal bearings to the yoke by using the large "C" clamp according to the following procedures:
- ① Install the base to the large "C" clamp proper.
 - ② Insert both bearings in the yoke, and hold and press-fit them by using the large "C" clamp. The guide of base stops the bearings at predetermined position.

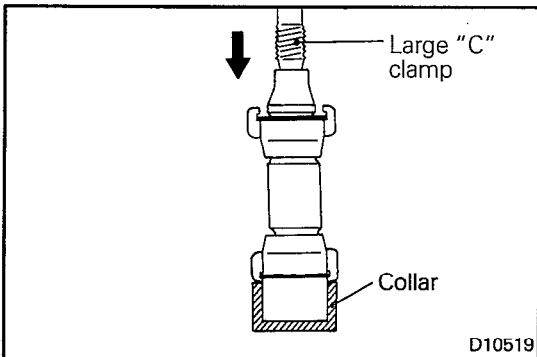

1. INSTALLATION OF SNAP RING

- (1) Fit snap rings of same thickness onto both sides of yoke.
- (2) Press the bearing and journal to one side by using the large "C" clamp.

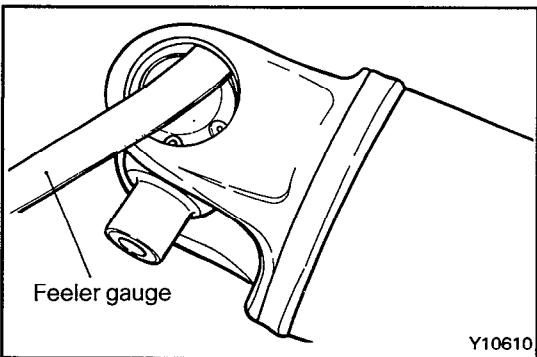

- (3) Measure the clearance between the snap ring and the groove wall of yoke with a feeler gauge.
- (4) If the clearance is more than the standard value, the snap rings should be replaced.
- (5) If the clearance is less than the standard value, the snap rings need not be changed.

Standard value: 0.06 mm (.0024 in.)

